

1986

The Earth Imperilled

Citation:

"The Earth Imperilled", 1986, Wilson Center Digital Archive, Vsevolod S. Avduyevsky and Anatoli I. Rudev, Novosti Press Agency Publishing House, 1986.
<https://wilson-center-digital-archive.dvincitest.com/document/110196>

Summary:

Pamphlet by the Soviet Novosti Press Agency arguing against the American "Star Wars" program. Advocates for the "Star Peace" program introduced by the Soviet Union.

Original Language:

English

Contents:

Original Scan

IMPERILLED

THE EARTH

Vsevolod Avduyevsky,
Anatoli Rudev

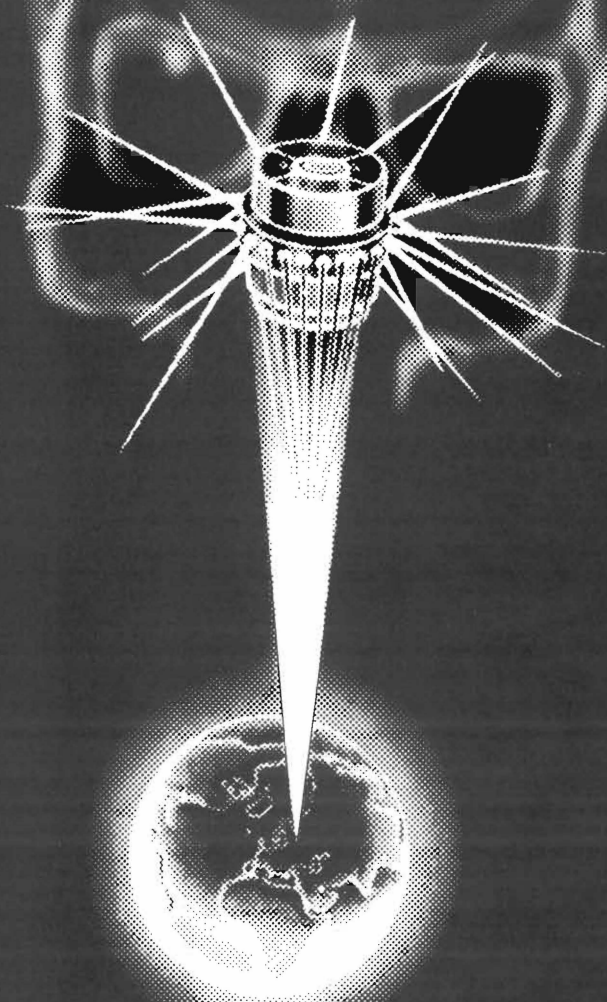

*Vsevolod Avduyevsky,
Anatoli Rudev*

THE EARTH IMPERILLED



Novosti Press Agency Publishing House
Moscow 1986

3607000000

CONTENTS

OUTER SPACE AT THE SERVICE OF MAN	5
A New Arena of International Co-operation	16
THE POLICY THAT DASHED ALL HOPES	20
Instruments of "Star Wars"	21
SDI and International Law	25
Error Will Be Fatal	26
The Ecological Aspect	27
The Militarisation of American Space Programmes	30
THE SOVIET "STAR PEACE" PROGRAMME	35
For a Peaceful Outer Space!	38

OUTER SPACE AT THE SERVICE OF MAN

“Man will not remain on earth forever. In pursuit of solar energy and space, he will first timidly reach beyond the atmosphere and then conquer the entire solar system.” When he made this prediction at the beginning of the twentieth century, Konstantin Tsiolkovsky, founder of modern theoretical cosmonautics, displayed great foresight. Some fifty years later it began to come true when the first artificial satellite was put into orbit from the Soviet Union’s territory in the early morning of October 4, 1957. A new era in the history of human civilisation, the era of space exploration, was ushered in. Three years later, on April 12, 1961, the first earthman, Yuri Gagarin, took off for his pioneer flight into outer space.

Space exploration is rapidly expanding. Following the Soviet satellite, *sputnik*, the United States, and, later a number of West European countries, as well as Japan, China, India, and Brazil, also put earth satellites into orbit. These are being joined by other countries which are launching ever more space stations with equipment for research, both theoretical and applied. These countries use foreign launch vehicles within the framework of international co-operation or on a commercial basis. Co-operation in outer space has become a vital factor in international affairs and its significance continues to grow.

What does man find so inviting about outer space? What does it have to offer people? What promising new aspects of its exploration are coming to the fore? To begin with, outer space is a totally new sphere of human activity. Thus it attracts people, as does everything unknown. A high vacuum, weightlessness, and the unlimited sources of solar energy provide favourable conditions for scientific experiments which would be either impossible or ineffective on earth.

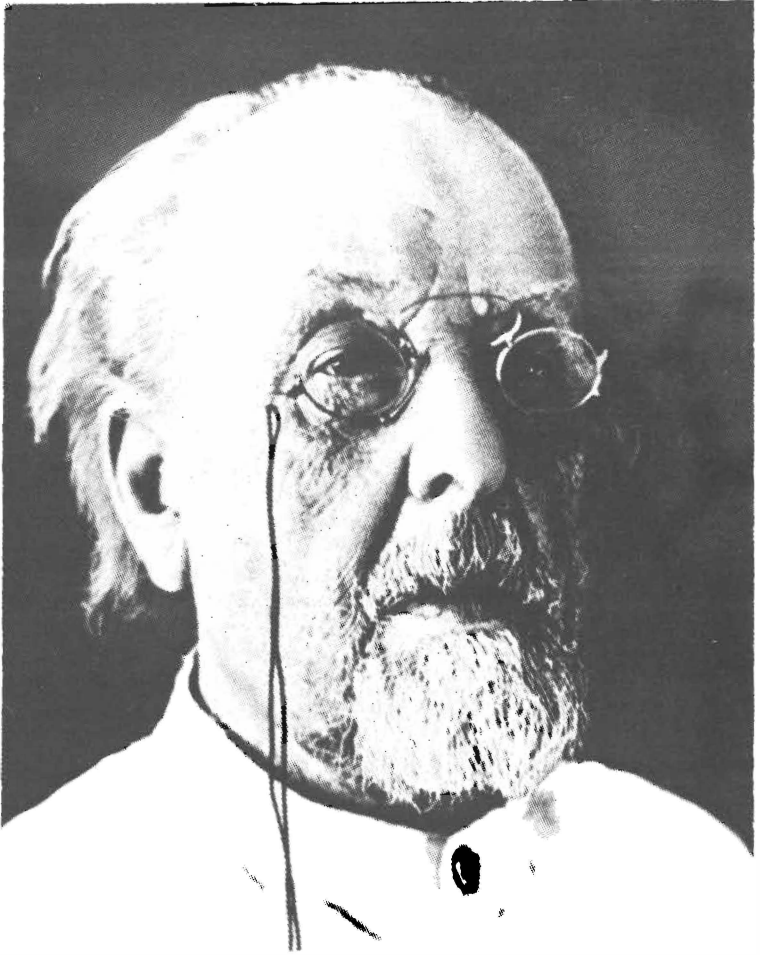

Konstantin Tsiolkovsky (1857-1935), a modest teacher of mathematics at a provincial school in Russia, was the founder of Soviet cosmonautics. He provided the theoretical substantiation for the design of spaceships and the technique of flights in interplanetary space as early as in 1896, believing that these would offer boundless vistas for the development of the earth's civilisation for the benefit and prosperity of man

Artificial satellites of the earth provide a convenient and economically expedient means of studying natural processes occurring on the surface of the planet and beneath it, in the atmosphere and near-earth space. Exploration in outer space has already made it possible to determine the dependence of natural phenomena on the activity of the sun and brought us nearer to understanding the causes of earthquakes, climatic changes and epidemics.

Scientific instruments applied outside the earth's atmosphere have made possible a number of fundamental discoveries in the field of astronomy.

Heavenly bodies now being put on the celestial map are characterised by such unusual conditions that they do not always fit into the framework of the known laws governing the behaviour of matter.

Exploration of the moon with the aid of space probes and the study of lunar rock samples back on earth have given rise to new theories of the origin of the Solar System and of the processes taking place on earth. Flights to the Moon, Mars and Venus, photographs of Halley's Comet, Jupiter, Saturn and their satellites made it possible to determine more accurately the age and stage of development of the entire Solar System. A solid foundation was laid for a new science, comparative planetology, vital for understanding the structure and evolution of our planet and for predicting its future.

Dozens of satellites launched by various countries are currently orbiting the earth. They are conducting research, and carrying out a wide range of tasks in the fields of communications, weather-forecasting, natural resources, etc.

Their usefulness is well demonstrated in the sphere of satellite **communications**, for example. To cover the entire globe (excluding the polar latitudes), it is sufficient to put just three satellites into geostationary orbit. They sort of hover over the equator at an altitude of about 40,000 kilometres at strictly designated points. Today's satellite systems maintain long-distance telephone and telegraph communications, and transmit photocopies of printed matter, data for computers, and television and radio broadcasts, thus making communication among people easier and more diversified and helping them cope with the increasing flow of scientific, technological and business information.

For the Soviet Union with its enormous territory, reliable communications are a matter of key importance; they determine the development of many regions. This purpose is served by satellites in the *Molniya* series placed in highly elliptical (elon-

gated) orbits and by the *Raduga*, *Ekran* and *Gorizont* geostationary satellites.

At present about 150 countries are employing the services of space communications. The manufacture and improvement of international space systems for various purposes is well under way in Europe, Asia, Africa, and Latin America (EUTELSAT, ARABSAT, AFROSAT, PALAPA, etc.). The *Intelsat*, *Intersputnik* and INMARSAT international communications and navigation systems have been functioning effectively for many years.

Space technology has considerably enlarged the potential of **meteorology** and made possible a marked improvement in the quality of weather-forecasting. In order to forecast weather for a 24-hour period at any one point it is necessary to obtain and analyse information on an area with a radius of 3,000 kilometres, while a forecast for several days in advance requires data on at least an entire hemisphere. So, satellites have become meteorologists' irreplaceable helpers. An orbiting satellite can scan about 10 per cent of the earth's surface in one revolution while in 24 hours its camera eye can take in the entire planet. And it gathers a hundred times more data than is received from all the ground weather stations over the same 24 hours. Specialists receive information—on the movement of cyclones and the formation of clouds—which is either impossible or difficult to obtain on earth.

The USSR has been operating the *Meteor* satellite weather system since 1967, which has made it possible to save a total of between 500 and 700 million roubles (about 1,000 million dollars) in our country alone.

A global system of weather observations has also been organised within the programme of the World Meteorological Organisation. It consists of weather satellites launched by the USSR, the USA, the European Space Agency, India, and Japan. These are used to monitor atmospheric processes over the entire planet. The countries involved operate more than 220 ground stations to receive data from weather satellites. All this helps a great deal to make more accurate weather forecasts and to study systematically climatic changes and environmental pollution.

Space probes can be used to study, quickly detect and even predict such natural calamities as floods, typhoons and volcanic eruptions, thus making it possible to either reduce or prevent their destructive consequences and save many human lives.

Information received from space vehicles used for the **study of the earth's natural resources** is also of enormous practical value. They determine the condition of forests and farmland, provide various information on the water flow in rivers, and study the resources of the World Ocean, to mention just a few things.

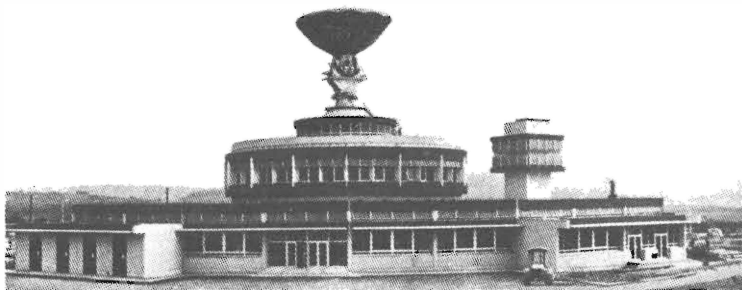

One of the many ground space communications stations serviced by Soviet satellites. It ensures reliable and uninterrupted communication of every type—from telegraph messages to the simultaneous relay of several colour television programmes

Such data are already being used by more than 800 organisations in the Soviet Union. Every year they receive from outer space more than a million photographs used for monitoring the condition of forests and the state of agrarian resources, for oil and gas prospecting, for planning roads, canals, oil and gas pipelines and hydropower stations as well as for developing remote and difficult-to-reach areas.

Preparations are in full swing for setting up international remote-control probing systems with the use of the *Kosmos*, *Meteor* and *Meteor-Priroda* satellites (the USSR), *Landsat* (the USA), *SPOT* (France), *MOS-1* (Japan), etc. Their use has made possible the development of a system whereby the environment and changes caused in it by man's technological activity can be monitored.

Satellites facilitate substantially increased precision in **navigational measurements**, make **navigation** safer and more economical. The navigational system involves measuring the parameters of the movement of any sea-going vessel in relation to navigation satellites with precisely determined orbits. In this way the onboard computer determines the ship's position and ultimately supplies the ship's geographic co-ordinates. The USSR operates the *Tsikada* navigation system based on the *Kosmos-1 000* satellites.

As examples of the effective use of navigation satellites we

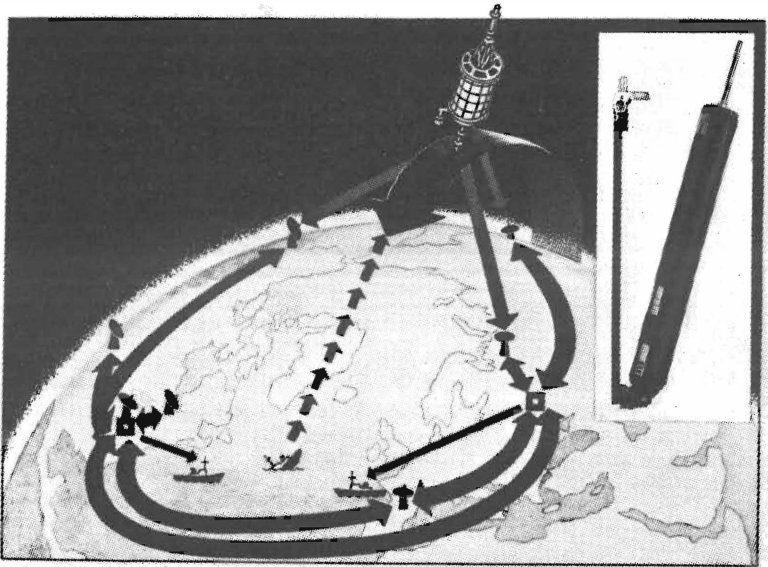

The orbiting satellites of the COSPAS-SARSAT international rescue service can pick up a signal from such a radio buoy at any point on the globe and instantly flash the exact co-ordinates of the place where assistance is needed to the rescue services

may mention the roles they played in directing the Soviet nuclear-powered ice-breaker *Arktika* precisely to the North Pole in 1977 and in rendering assistance to the Soviet research vessel *Mikhail Somov* caught in an ice jam off the Antarctic coast in 1985. The growing role of space technology in sea navigation has led to the formation of INMARSAT, the international marine navigation satellite system.

Naturally, aircraft—and any other means of transportation for that matter—can also use the services of navigation satellites.

Every year approximately 350 ships sink on the high seas. Ten per cent of them disappear without a trace, never having even sent a distress signal. The existing rescue service, despite the considerable progress achieved, remains insufficiently effective, and often help arrives too late.

Rescue satellites can effectively cope with this problem. A distress signal sent by an emergency radio buoy in any part of the world is received by a satellite and instantly processed by its onboard computer, and flashed to the alert network in the form of the precise co-ordinates of the scene of the accident. There is no

need to search. The rescue facilities are immediately rushed to the exact spot.

The international rescue COSPAS-SARSAT system has been successfully operating since September 1982. Based on Soviet and American satellites keeping constant watch in orbit, and ground receiving stations in the USSR, the USA, Norway, France, Canada, and Great Britain, the system now monitors more than 70 per cent of the Northern Hemisphere which has the heaviest air and sea traffic. With time, the system is expected to service the entire globe. According to incomplete data, in the first four years of its existence the system has helped rescue more than 650 people in various parts of the world—on land and at sea.

Progress in science and technology is largely dependent on the materials man uses in his activity. In the past new materials, such as bronze and iron, led to great leaps in the development of civilisation.

The present day is characterised by the need for controlled-property materials and those which do not exist in nature. We have found them to be indispensable for the perfection of machines, equipment, drugs or fertiliser. And, in the long run, it is on materials that scientific, technological and economic progress depends.

So, no sooner had the technique of space flights been mastered than there appeared a keen interest in the use of weightlessness on spacecraft. It was seen as a possible way of considerably improving the technique of creating **new materials**. The point is that most materials go through a liquid or gaseous state in the process of manufacture. Here on earth a movement in a liquid or gas is self-induced by the force of gravity—a natural convection leading to the stratification of alloys, disruptions in the structure of materials in solidification, and the uneven distribution of doping additives. The result is that the properties of the materials turn out to be of considerably poorer quality than anticipated. Moreover, in earthly conditions liquid substances coming in contact with the walls of the vessel become polluted by them or may enter into chemical reactions with them.

In the conditions of weightlessness natural convection is easily eliminated. As a result, it becomes possible, for instance, to grow perfect semi-conductor crystals and obtain ideal metal alloys. In outer space it is also possible to isolate totally pure drugs from a mixture of protein compounds in the electric field. This is of great interest to medicine. And there are numerous other examples of the benefits of this process.

Crystals capable of introducing significant progress in electronics have already been grown within the framework of the

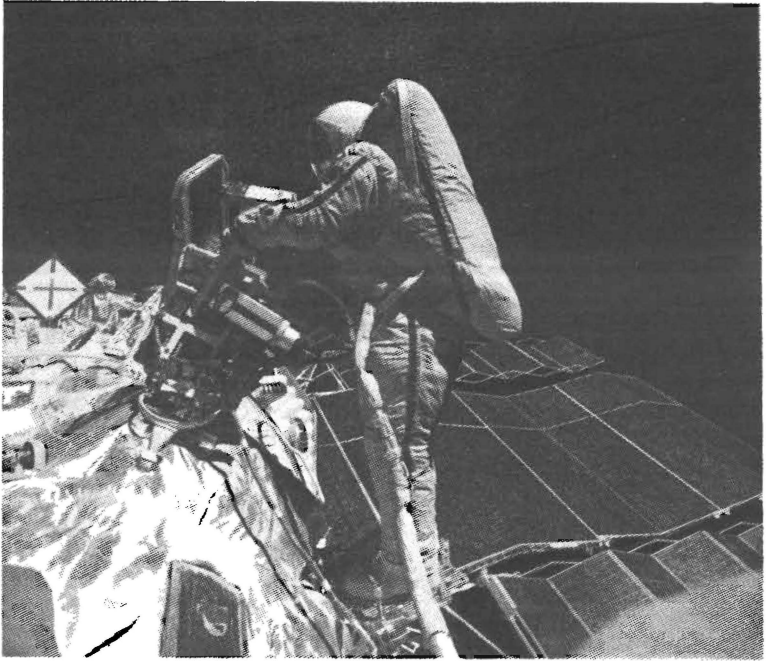

The first earthwoman face to face with the universe: Svetlana Savitskaya outside the Salyut-7 Soviet orbital station experiments with metal treatment in open space

Soviet programmes of technological experiments in outer space. New materials and alloys with remarkable properties, and new biologically active drugs have been obtained.

Manned flights on long-term orbital stations and transport spacecraft have become the most important achievements of modern space technology and the mainline of its development. The use of increasingly precise scientific instruments, computers and automatic experimental data processing undoubtedly enhances the efficiency of space research. But of course man cannot be replaced always and everywhere. Man is the primary creative force in science. No instrument, no set of instruments can in the final analysis replace the intellect, perception or intuition of the experimenter. The success attained through the use of unmanned space probes is undeniable; the course of their further development is visible. However, no matter how rapidly the number of reliable unmanned probes increases, the future of cosmonautics

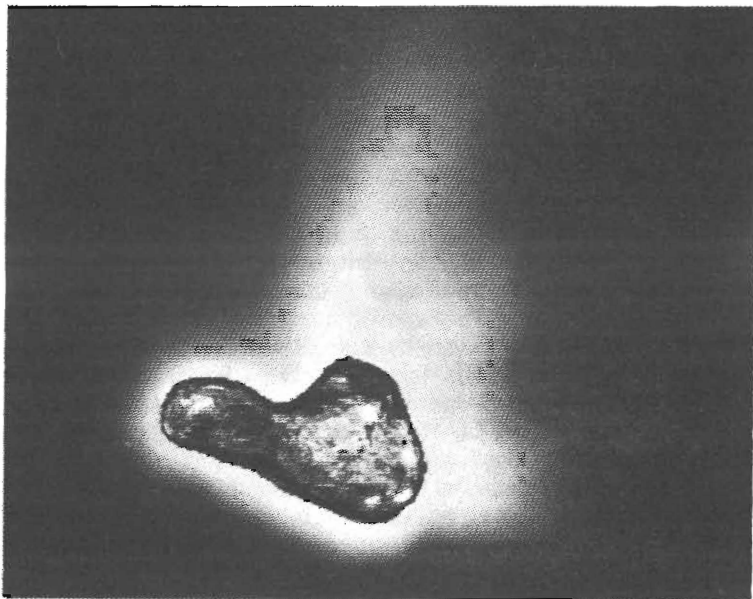

The nucleus of Halley's Comet as seen by instruments installed on two Soviet unmanned space probes, Vega-1 and Vega-2, during the rendezvous with the comet in March 1986. The size of the nucleus was 16 by 8 kilometres. Its mass, consisting of water, ice with inserted silicate, carbon and metallic particles, weighed approximately 1,500 million tons. This was the type of protomatter from which the Solar System was formed 4,500 million years ago

will be determined by progress in manned flights. The Soviet Union has made a tremendous contribution towards resolving the problems involved in manned flights. It has covered the path from Gagarin's 108-minute solo flight aboard the *Vostok* spaceship to the longest expedition in space history—the 237-day flight made by Leonid Kizim, Vladimir Solovyov and Oleg Atkov on the *Salyut-7*—*Soyuz* orbital research complex, and, later, to the epoch-making flight by two cosmonauts from the new *Mir* orbital station to the *Salyut-7* and back.

The first steps on the moon by American astronauts Neil Armstrong and Edwin Aldrin and the journeys into outer space made by the first squadron of American space shuttles have gone down in mankind's history forever.

There have been people working in terrestrial orbit almost continuously in recent years. More than 200 people have been up

in space since Gagarin's pioneer flight. Their total combined stay there is approaching 20 years.

What specialists have achieved on orbital research complexes in such key areas of science and technology as geophysics, the study of the earth's resources and atmosphere, astrophysics, medicine and biology has proved extremely productive. Extravehicular assembly and repair work carried out by cosmonauts has proved, for instance, that welding and many other operations can be successfully carried out in open space. The experience gained is invaluable for the operation of future orbital stations and the assembling of large complexes in near-earth orbit.

It is expected that before too long the creation of space complexes will be followed by that of large systems or super-systems. The latter will be called upon to link together space complexes, ground and orbital flight control, information receiving and processing centres, and to feed the information into data banks accessible to users around the world.

Combining space technology and microelectronics will eventually make it possible to speak of a global information network, that is, of an **integrated information field** which would enable anyone anywhere in the world to plug into it at any time. This would lead to a drastic change in the way of life of many millions of people.

All will have access to the treasures of world science, technology and culture—from the collections of the world's greatest libraries and museums (one will be able to "visit" the Hermitage and the Louvre at any time) to the stores of the greatest private or state-owned film libraries, to say nothing of various reference data, recommendations on the treatment of diseases, and other types of information. In many cases scientists will not have to travel at all to attend conferences, symposiums or colloquiums or to keep in touch with one another. They will only have to dial a code to contact the desired party. We are talking here about a giant leap in the progress of civilisation.

Space technology opens the door to the practically unlimited resources of **solar energy**. A reflector satellite or an "artificial sun" sending rays to the earth is becoming a real possibility. By reflecting the sun's rays to designated areas, it can prolong daylight in places where this might be necessary—large construction sites, farms during the sowing or harvesting seasons, areas stricken by natural calamities where rescue or rehabilitation work is under way, Arctic regions, etc. It can also speed up plant growth and help combat morning frosts. It is believed that the use of space reflectors may become a feasible and expedient proposition in the near future. Estimates show that the drop in the

demand for electric power of five cities the size of Moscow as a result of lighting from outer space would be great enough to pay off the cost of orbital reflectors in four to five years.

The creation of orbital power stations which transform solar radiation directly into electricity also deserves special attention. **Space power engineering** is called upon to serve as a base for industrialising the earth's environs. As a long-term prospect, we can envisage the building of orbital factories and plants for manufacturing new materials and other industrial products in the conditions of a high vacuum and weightlessness. Conditions will be created to replace ecologically harmful and air-polluting industries with clean waste-free ones. The **industrialisation of outer space**, for its part, will lead to unprecedented development in the productive forces, becoming the mainline of scientific and technological progress. It will make possible the solution of key problems of mankind's economic advancement.

The role played by man's activity in outer space is rapidly increasing. The relatively small long-term space labs of the type of the Soviet *Mir* station are expected to come into wide use in the near future. They are designed to allow for the attachment of five or six of the most varied devices or units. It is anticipated that these stations will eventually turn into large-size **space complexes** with a wide range of amenities. The complexes will consist of various research, industrial, living, and medical units.

The medical units of the orbital complexes can be turned into **space clinics and rest-and-cure centres** providing treatment, and not only for cosmonauts but also for other people suffering from ailments curable in conditions of weightlessness. Some medical specialists believe that the course of such ailments as bronchial disorders, tuberculosis, hypertension, polio, diseases of the spinal chord, burns, etc. may be greatly influenced by changes in the earth's gravitational pull. Such changes may facilitate the speedy recovery of patients at the space clinics.

And the time is not far off when **space tours** will become routine.

In the more distant future, when man will venture deeper into space, unravelling its mysteries, conditions will be created for the **space settlements** Tsiolkovsky predicted. It will become possible to explore the moon and other celestial bodies and their resources on a large scale and to carry out the most daring projects.

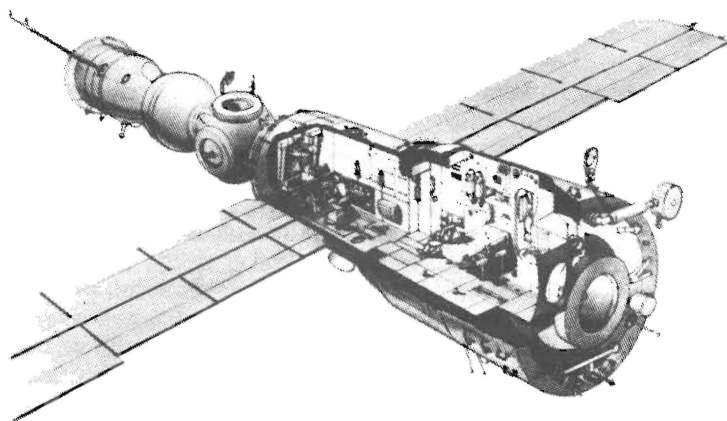

The Soviet new-generation orbital station Mir capable of docking with five different cargo or research modules. These will possibly include the Hermes spacecraft now being developed by the European Space Agency

A New Arena of International Co-operation

Nowadays no country in the world, no matter how great its economic, scientific, technological or intellectual potentialities, can cover every sphere of space research on its own. Nor can it solve in full any of the urgent problems of utilising on a global scale the achievements made by applied cosmonautics. And, of course, all countries are attracted by the fascinating prospects their participation in space projects offers them. And here, too, the Soviet Union acts as the pioneer of co-operation.

From 1978 to 1981 citizens from all the socialist community countries took part in manned flights together with Soviet cosmonauts on the *Soyuz* spaceships and the *Salyut-6* orbital station within the framework of the Interkosmos programme. The international crews have carried out about 150 experiments and studies which are of major scientific and economic importance to their countries.

The programmes of joint space flights undertaken with France and India have also proved a great success. An international crew including a French citizen carried out a space mission on the



The emblem of the Interkosmos programme is on the space-suit of every member of the international crews working on the Salyut-Soyuz orbital research stations. Among them, in addition to Soviet cosmonauts, there have been citizens of Bulgaria, Cuba, Czechoslovakia, the GDR, Hungary, Mongolia, Poland, Romania, and Vietnam, as well as of France and India

Salyut-7—Soyuz orbital complex in June 1982. It became a major achievement in space research. The flight of the Soviet-Indian crew in April 1984 became a symbol of the growing friendship between the USSR and India. In the course of the preparations for the flights and during the missions themselves, both French and Indian specialists and cosmonauts not only obtained interesting results in the fields of space technology, astrophysics, the exploration of natural resources, medicine, etc.; they also acquired valuable experience which will undoubtedly help those countries to develop their own space science and technology.

The joint Soviet-American manned space flight, known as the Apollo-Soyuz Test Project (ASTP), became a real milestone and received international recognition. The July 1975 link-up of the *Soyuz* and *Apollo* spacecraft of the USSR and the USA, the two leaders in space research, and the smooth work of the mixed crew

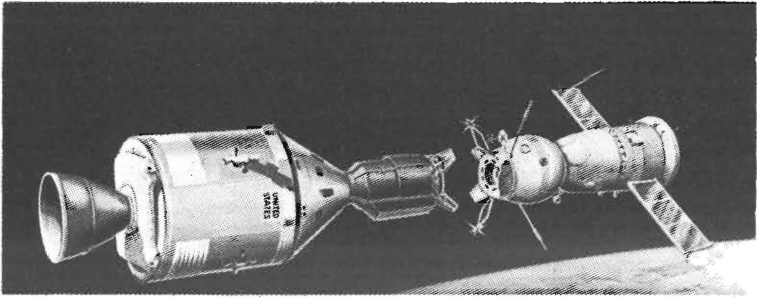

The space symbol of detente and peaceful coexistence—the link-up of the Soyuz and Apollo spacecraft under the Soviet-American programme for the joint study of outer space

on board the international manned complex were not only a highlight in the history of cosmonautics and a major step towards co-operation in outer space. They also made a tangible contribution to detente. Had the American side not begun to undermine detente and scale down Soviet-American relations, agreements on developing co-operation in the peaceful exploration of outer space could have been realised.

There are many areas in the non-military exploitation of outer space in which the USSR, the USA and other interested countries could work productively together. Take, for instance, the extremely interesting problem of a manned flight to Mars. The project is already technically quite feasible. Of course, such an expedition would involve enormous cost, and it would be difficult for any one country to cope with the task alone. However, if the efforts of several countries were pooled, as was the case, for instance, with the *Soyuz-Apollo* project, a trip to Mars would become a reality. There are also many other, fascinating projects which would also require joint effort: the establishment of permanent manned research bases on the moon, the construction of an orbital institute far from earth, etc.

Various international governmental organisations have an extremely important role to play in initiating and promoting co-operation. And there is no doubt that the United Nations ranks first among them. It is within the framework of this world body that a wide range of problems concerning space exploration is discussed—from organisational, political and legal matters to scientific and technological issues. This applies to the sessions of the General Assembly, the First Committee, the Special Political

Committee, the UN Committee on the Peaceful Uses of Outer Space, its Scientific and Technical and Legal Sub-Committees as well as the UN conferences on the exploration and utilisation of outer space for peaceful purposes.

An important part is played by international non-governmental scientific organisations. Their members are research societies, unions, offices, and individual scientists, not states. Among the particularly prestigious organisations of this type are the Committee on Space Research (COSPAR) of the International Council of Scientific Unions and the International Astronautical Federation (IAF).

So, although there is a widely ramified organisational structure of international co-operation in space research, it does not always measure up to its tasks. Nor are Soviet and US achievements in space exploration used to their fullest potential in the interests of all countries.

In this connection the fact that the USA, the leading capitalist power, has been striving for military strategic superiority in recent years cannot but arouse concern. The United States is attempting to achieve this superiority by extending the arms race to new spheres, including outer space. If space-strike weapons were developed and deployed, it would become impossible to realise the encouraging prospects of peaceful co-operation in outer space and would create a major threat to the very existence of mankind.

THE POLICY THAT DASHED ALL HOPES

On March 23, 1983, in a televised address to his fellow-citizens, President Reagan announced his intention to change the course of history. And he decided to do so with the help of the scientists who gave the United States nuclear weapons. How? In a very simple way: "To turn their great talents to the cause of mankind and world peace: to give us [the US] the means of rendering these nuclear weapons impotent and obsolete." The President said nothing in his address about the actual technical means of solving the problem. These were specified two days later in Presidential Directive No. 119 and also described in detail by members of the US Administration close to the President. In concrete terms, the programme announced by the President is aimed at developing ABM defence for the United States and its allies and has been officially named the "strategic defence initiative" (SDI).

According to its architects, the idea of SDI is to neutralise strategic nuclear missiles to "render them obsolete". This is a multiple-tiered system of antimissile defence involving hundreds of space vehicles equipped with "third-generation" beam weapons capable of destroying ballistic missiles and their warheads at any leg of their flight path, from take-off to target approach. These weapons are also designed to hit any objects in space and can be used against planes and targets on the ground.

The development of SDI will result in a dangerous qualitative leap in the nature of war, make it all-embracing and involving a new sphere—outer space. That is why SDI has been aptly nicknamed "Star Wars" after the popular Hollywood film.

The fact that there are incredibly huge nuclear arsenals in the world closely linked with space technology and outer space gives rise to extremely serious misgivings, for even a minor accident—a

short circuit or mere negligence in controlling military-space systems—may set off a terrible force and destroy all living things on earth. It must be pointed out that those whom the American President was addressing in his impassioned appeal—many of them at any rate—were quick to respond to it, although their response was quite different from what was expected. The deployment and even testing of weapons in space, they said, would considerably increase the probability of war on earth.

The ABM network outlined in the SDI programme constitutes a fundamentally new system of strategic weapons and is in fact called upon to supplement the triad of the American strategic forces consisting of ICBMs, nuclear-missile submarines and nuclear-capable aircraft, as well as the American medium-range ballistic missiles being deployed in West European countries.

The US leadership's blind devotion to SDI blocks detente like an Arctic frost, breaks and cripples existing agreements on curbing the arms race, and puts up a solid wall in the way of adopting new peace projects and initiatives. A striking case in point was the stand adopted by President Reagan at the meeting with Mikhail Gorbachev, General Secretary of the CPSU Central Committee, at Reykjavik in October 1986. President Reagan's attitude dashed the hopes of the entire world for significant progress in adopting major historic decisions on a considerable reduction in nuclear weapons, decisions based on the Soviet Union's proposals at the meeting. Washington is guided by its well-known maxim "He who dominates outer space will dominate the earth." And since the US Administration, having come to believe in its technological superiority, is seeking a breakthrough to military superiority through SDI, it chose to reject these agreements that had almost been reached. Mikhail Gorbachev pointed this out immediately following the Reykjavik talks.

In a bid to whitewash his stand at those talks the US President described SDI as America's "insurance policy". How does Washington intend to insure its country and people, and against what? It intends to do so by searching for more and more instruments of destruction and war, which are ever more refined, fast-acting and inaccessible in all the conceivable spheres of application.

Instruments of "Star Wars"

In the Pentagon's view, **laser weapons** would be ideal for "Star Wars". A laser can send a narrow beam through thousands of kilometres essentially unhindered in the vacuum of space.

The main research objective in the SDI programme is to obtain

high-energy laser beams with a minimum dispersion and accurate guidance on targets three to five thousand kilometres away.

In accordance with the SDI programme, chemical, excimer and free-electron lasers differing in the methods of beam generation and in wavelength are viewed as the main components of the system. A laser beam can burn through the outer casing of its target over a long distance, destroying or neutralising its vital systems, igniting fuel, causing an explosion, etc.

Those who advocate the development of laser weapons and their deployment in outer space maintain that problems arising in the course of research and development are not insurmountable at the present level of science and technology. The United States has already conducted a number of ground tests of chemical lasers which, according to press reports, have confirmed their ability to hit missiles and planes.

X-ray lasers constitute another direction of research and development being conducted in the United States in the sphere of space weapons. As opposed to chemical lasers, which destroy targets by heat, X-ray lasers are powered by a nuclear explosion. The induced X-rays are focused through hundreds of discharge tubes into narrow beams of high destructive power which are then directed at their targets.

The US Congress was informed about the first successful test of an X-ray nuclear device in February 1981. The following summer a drive was launched to convince President Reagan of the need to develop space-based X-ray lasers.

Immediately there appeared programmes for placing hundreds of X-ray lasers in low earth orbit. It was alleged that each of them could destroy 10 to 100 missiles within the first minutes of their launch with just one "shot". The authors of those projects point out that such laser installations are very compact. In their view, this makes it possible to fill outer space with those things in 10 to 20 trips of a space shuttle or send them to "waiting orbits" via serial ballistic missiles.

The underground nuclear tests being conducted in Nevada in spite of the Soviet unilateral moratorium on all nuclear explosions, which was announced in August 1985 and has been extended many times since, are said to be directly linked with the development of combat X-ray lasers.

Possibilities are also being examined for using the **electromagnetic impulse (EMI)** created in a nuclear explosion. The EMI can cause overloads in electric circuits and put out of action electronic systems and power transmission lines on an entire continent. The EMI impact can disrupt telephone and radio communications, put out of action communications satellites and

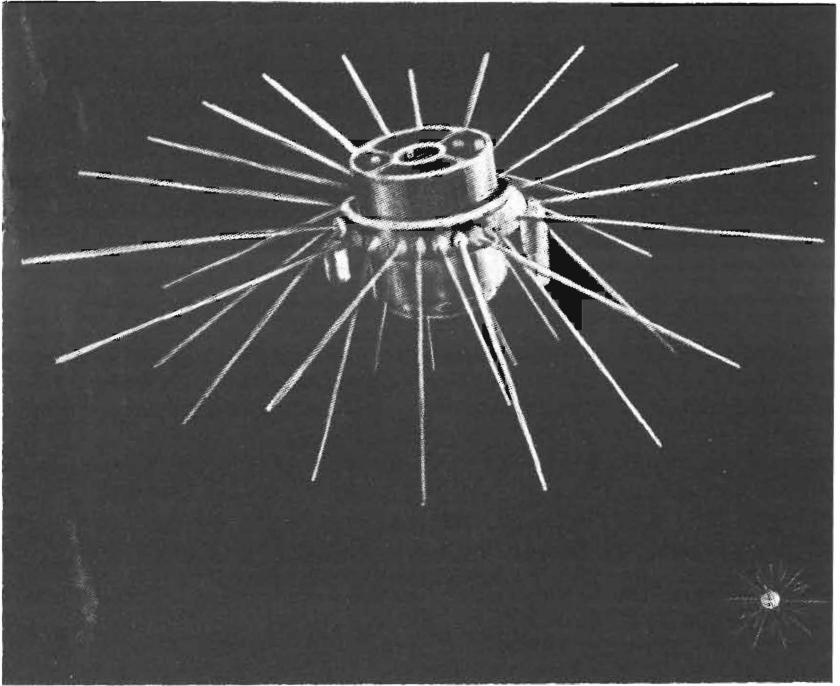

A strike weapon from the "Star Wars" arsenal—a combat orbital installation with an X-ray nuclear-powered laser

electronic control systems, computers and so on, as well as disorganise air and ground traffic.

However, scientists and other specialists have proved that it will be virtually impossible to set up a system capable of destroying all missiles in boost phase within the next few decades if at all. No matter how much money is spent on this system, there can be no guarantee that some of the 10 to 20 thousand nuclear warheads flying simultaneously will not break through the "space shield". And that would be enough to cause irreparable damage.

It has also been found that many of the proposed space weapons are *a priori* vulnerable, while means of countering them may prove much more effective and cheaper. While advocating the development and deployment of a large-scale space-based ABM system, the American President himself admits that this system has some intrinsic shortcomings which lead to problems and uncertainty.

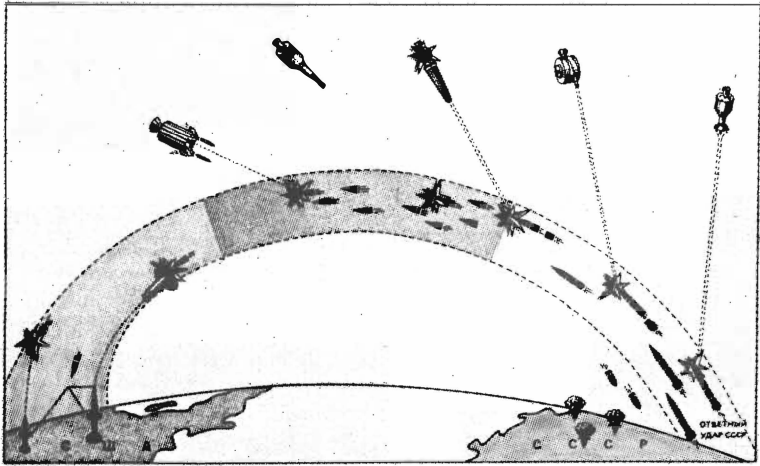

The chart of one of the versions of the American ABM system with space-based elements

There is no doubt that from the technical point of view SDI does not guarantee US security. On the contrary, Washington's "defence initiative" gives nuclear power, excessive as it is, literally cosmic prospects. Moreover, SDI compels the USSR to design a programme of its own to counter it, a programme which will be no less effective and, as the Soviet leadership has pointed out, simpler and cheaper.

It would also be wrong to ignore the fact that the growing militarisation of outer space will inevitably involve third countries and will become increasingly difficult to stop.

In June 1985 the countries of Western Europe agreed to France's proposal to set up the European Technological Community within the framework of the Eureka programme. The latter provides for joint efforts in the field of research and the peaceful exploitation of the latest achievements in a number of promising branches of science, including the use of lasers and directed-particle beams for the treatment of various materials and welding, the development of new communications systems, the production of new structural materials, etc.

We cannot very well exclude the possibility that the Eureka programme, conceived as a "technological reply to the American challenge", may eventually become the European version of the American "Star Wars" project. The NATO countries are already carrying out considerable work in this area. For instance, the FRG

has already worked out a concrete programme for developing a system to destroy missiles and planes with the aid of lasers and electromagnetic guns. France and Italy are conducting joint research into an "electronic warfare" system. Research in other areas of the latest armaments is also well under way in Western Europe.

If the arms race is allowed to spread to outer space, it will destabilise the world situation, make peace even more fragile. Space technology makes the nuclear weapon arsenal ever more sophisticated. This is sure to complicate or even make impossible the reaching of international agreements on its limitation and reduction. The system of international accords set up as a result of the efforts of states undertaken in the course of many years will be frustrated, while attempts to build confidence between the nuclear powers and achieve arms limitations and reductions will be undermined.

SDI and International Law

The claim that the US "strategic defence initiative" is in line with the principles and standards of international space law is without substance. A cursory glance at them is enough to see that the "Star Wars" plans either contravene the existing international agreements on outer space or pose a threat to the prospects of concluding vital new agreements on the exploration and utilisation of outer space for peaceful purposes.

The Treaty Banning Nuclear Weapon Tests in the Atmosphere, in Outer Space and Under Water (1963) already contained provisions, legally binding for its participants (including the USA), which excluded the new area of human activity, outer space, from the sphere of nuclear explosive devices.

The fundamentals of international space law were laid down by the **Treaty on Principles Governing the Activities of States in the Exploration and Use of Outer Space, Including the Moon and Other Celestial Bodies, concluded in 1967 ("the Space Treaty")**. This treaty forbids the placement into orbit around the earth or in outer space of any objects with nuclear weapons or any other weapons of mass destruction on board. Any violation of this provision incurs responsibility in terms of international law.

The Agreement on the Activity of States on the Moon and Other Celestial Bodies signed in 1979 extends and specifies the appropriate provisions of the Space Treaty. It reiterates the principle formalised in the latter that the moon and

other celestial bodies be used for peaceful purposes alone and extends it to include orbits around the moon and other celestial bodies as well as other flight paths to or around the moon and other celestial bodies.

As for the **open-ended Treaty Between the Union of Soviet Socialist Republics and the United States of America on the Limitation of Anti-Ballistic Missile Systems (ABM Treaty), 1972**, it constitutes the main legal obstacle to the spread of the arms race into outer space today. The United States intentions to create a large-scale space-based ABM system blatantly defy its provisions prohibiting both sides to develop, test or deploy sea, air, space or mobile ground-based ABM systems or their components. The ABM space-based components were acknowledged as dangerously destabilising and therefore impermissible.

The Convention on the Prohibition of Military or Any Other Hostile Use of Environmental Modification Techniques (1977) is aimed at preventing the use of space weapons and new methods of warfare. It prohibits states from using the above-described environmental modification techniques, which may have large-scale long-term or serious consequences, as a means of inflicting damage on any other participating state. Outer space, as we have seen, is part of the environment.

Rapid destruction of the **atmosphere** (for instance, the magnetosphere, the ozone layer and other areas or components of the earth's atmosphere and the space adjacent to it) and qualitative changes in its composition and the mechanism of its processes shaped in the course of millions of years may prove irreparable. For the evolution of the atmosphere may take a new, unknown course in which there will be no place for man.

Error Will Be Fatal

When outer space becomes filled with extremely sophisticated weaponry, mankind will have to live with the ever-present threat of nuclear war breaking out as a result of an accident. The point in deploying refined new types and systems of weapons is that they will always be ready to deliver a strike. The time it takes for them to react is measured in minutes or even seconds, seconds that would separate the world from a nuclear holocaust. The chances of preventing it would be practically nil. There would be no time to assess the situation in the event of a false alarm. Paradoxically, neither parliaments nor governments, empowered by their con-

stitutions to decide the question of war and peace, would be able to control the fatal march of events.

Examples of nuclear weapons accidents in various parts of the world and cases of false missile alarms are numerous and well known. It has so far been possible to prevent dangerous consequences of these incidents because political and military leaderships have had enough time to evaluate the situation. The space-strike systems will operate at such speeds that leaders will have no time to think twice.

Once put into motion, the operation of sophisticated systems is impossible to alter. The worst misgivings on this score were confirmed on January 28, 1986 when the *Challenger* space shuttle malfunctioned and was destroyed, killing the seven people on board. Given that such a mishap befell a well-tested and tuned-up spaceship, the question arises of whether one can rely on trouble-free operation of computer complexes as they grow increasingly more sophisticated. Precisely such complexes are intended to operate space-based strategic strike weapons, weapons that can be tested but once in real-life conditions.

Military spacecraft may not differ significantly from non-military vehicles in appearance or behaviour in orbit. Therefore when strike weapons are put into orbit, any space vehicle will become subject to suspicion. This will make it necessary to develop detector and killer satellites, "space mines" and other vehicles that will react to every foreign spacecraft as a potential target. One can imagine the state of cosmonauts on board a peaceful manned orbital complex when an armed observer or automatic combat vehicle will be circling the earth beside them.

And how will people on earth feel, knowing that hundreds of spacecraft with all sorts of weapons are hovering above them?

The Ecological Aspect

It is growing ever more apparent that nature has begun to "avenge itself" on man for exhausting resources that seemed limitless only a short while ago, for causing the disappearance of entire species of plants and animals, soil erosion, changes in the water balance and even in the climate. Mankind should not allow anything of the kind to happen to outer space, if only out of an instinct for self-preservation. Outer space remains a mystery in many respects; its exploration is still in the infancy stages. So, no matter what heights man might achieve in this new sphere of activity, he must not delude himself. The consequences may come later.

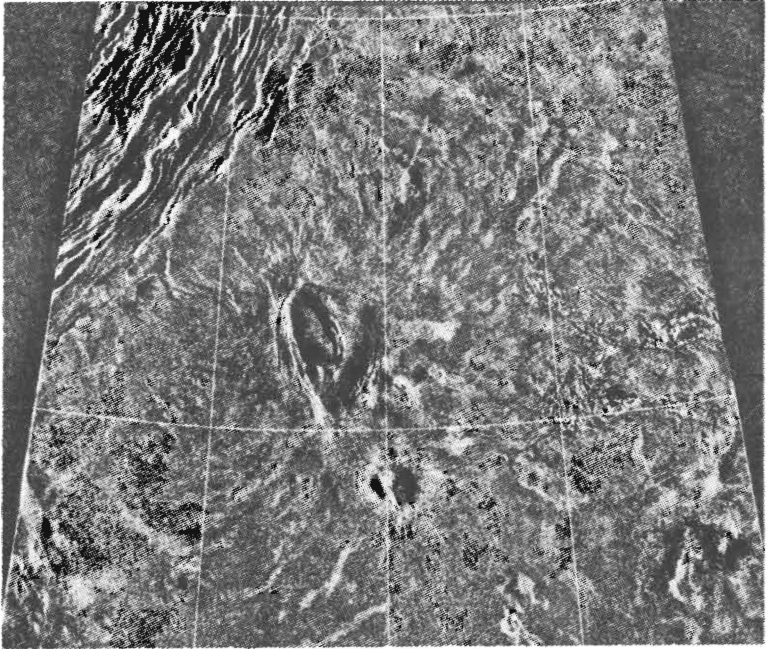

The barren landscape of Venus' hot surface and (on the right) a space photographer—the Soviet Venera-15 interplanetary station

Space exploration has shown that Earth is the only planet in the Solar System capable of supporting life. The evolution of the other planets is proceeding in quite different directions. Unlike Earth with its biosphere, the other planets are characterised by barren deserts. It must not be forgotten, however, that during the Ice Age of the earth's history the climate approached the limits of endurance for all living beings.

Man is part of the biosphere. He makes extensive use of the earth's wealth yielded by its plant life, which has been processing solar energy for millions of years. All we have today—the oxygen we breathe, the ozone layer that protects us from deadly ultra-violet rays, our food, our climate—has been produced by the earth's unique system of absorbing solar energy.

Man has been inseparably linked with nature in the course of his evolution and there are still no grounds to believe that he will ever become independent of it. Most likely this is impossible and inexpedient anyway.

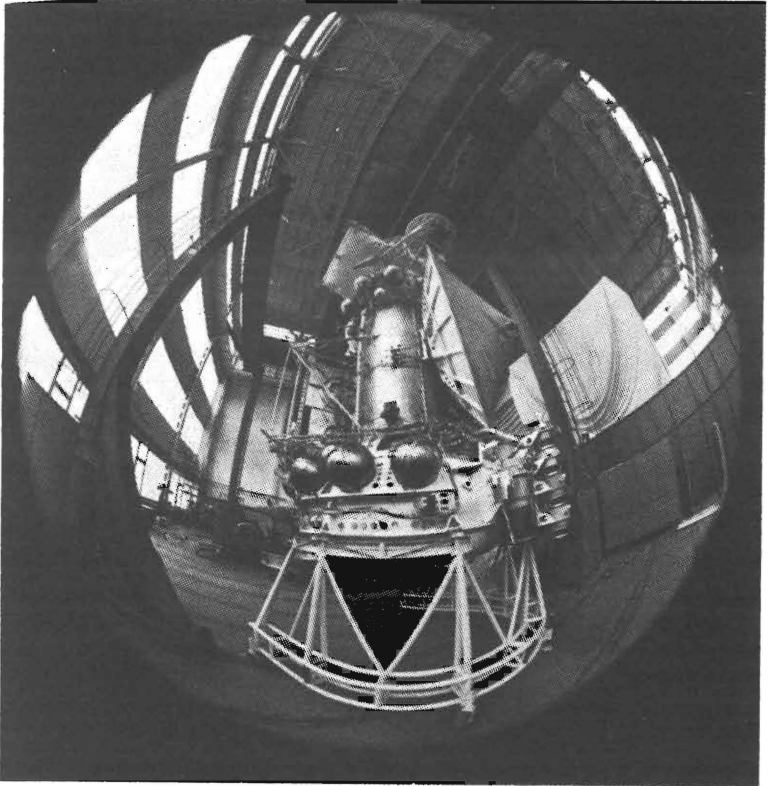

And even when other sources of energy (the energy of controlled thermonuclear reactions, the earth's inner energy) come to be used on a wide scale, when we learn to effectively store solar energy and obtain enough oxygen for breathing, we shall not be able to isolate ourselves from living nature around us. It is this nature that has guaranteed equilibrium on earth and in the space around it, processing organic wastes and the products of their decomposition and returning them to us in the form of clean air and water through the ecological cycle. Man would have perished in his own waste without that. So, mankind must maintain this equilibrium first and foremost in order to survive and go on living in the changing conditions.

Today the prevention of the potentially dangerous consequences of activity in outer space is one of the mandatory and commonly acknowledged principles of international law enshrined in the 1967 Space Treaty and the 1977 Convention

banning the military or any other hostile use of environmental modification techniques. However, if the arms race spreads to outer space, the number of military objects being launched and of tests of ever more new types of space weapons will increase dramatically. It is not difficult to foresee the emergence and deployment of space-based systems invisible to modern radars, such as the so-called "Stealth" satellites made of materials absorbing radar signals; manoeuvring and reserve satellites placed either in orbits difficult to reach with countermeasures or deep in space, etc. Such rapid and profound changes in military technology will make it exceedingly difficult or even impossible to control. In a number of cases the potentially disastrous consequences will be difficult to foresee and even more difficult to prevent or significantly reduce. As a result, they may dangerously upset the fine and unique natural equilibrium both on earth and in the space around it.

In a number of areas the arms race has already approached a point beyond which it may become impossible to curb by means of international agreements based on control.

In this connection the development, testing and deployment of new types of "Star Wars" weapons is an outright attempt to undermine world peace and security, a process which will imperil the planet Earth.

The Militarisation of American Space Programmes

The US ruling circles' militarist designs in regard to outer space did not just suddenly appear one day. Within the first few years after World War II the munitions corporations and the Pentagon began to study the possibilities of making combat systems for dealing blows to the enemy from space vehicles and destroying his objects in outer space. Among the projects considered in the '50s and '60s were systems of unmanned spacecraft for detecting and destroying enemy satellites, the X-20 space plane, the *Orion* heavy-duty nuclear propelled launch vehicle, the XB-70 supersonic bomber for launching booster rockets in the air, etc. There were also projects to set up a belt of man-made meteorites, a kind of "mine-field" in outer space, all sorts of booby traps, decoys, etc.

In addition, there were plans to set up giant orbital military stations and missile bases on the moon, to use asteroids as "space bombs" by redirecting their flight paths towards enemy territory, to wage geophysical warfare, etc.

However, in those days such projects, in view of their extreme complexity, proved to be beyond the capabilities of even such a developed and wealthy country as the United States. Moreover, the emerging military-strategic parity in the world had a sobering effect on the American ruling circles. And they were stunned by the USSR's historic successes in the peaceful exploration of outer space. In order to re-establish its declining prestige, the United States was compelled to turn to civilian space research programmes, which undoubtedly gave a fresh impetus to space research.

It was at this time that a number of international space programmes involving Soviet and US participation were carried out successfully. Bilateral co-operation reached its height with the *Soyuz-Apollo* test project. However, immediately following the completion of this project, in 1976, the US Administration began either dramatically reducing or cancelling joint ventures in outer space.

Soviet-American co-operation in space projects was scaled down because it did not fit in with the ambitious schemes of some US circles for attaining military superiority. They were obviously displeased with the rough military-strategic parity achieved in the world, the process of detente and the shaping up of agreements on the limitation of strategic armaments. Under the influence of these circles interest is being revived in the United States in the various ways to wage a nuclear war, changes are being introduced into American nuclear strategy, and military preparations in outer space are being speeded up. Approximately half of the military space probes launched in the United States are reconnaissance satellites, and particular importance is attached to their use. In addition to gathering military intelligence, they are employed to assess the economic potentialities of the socialist countries, their natural resources, etc.

The United States began showing interest in the schemes to put large stations in low earth orbit as early as 1948. In the '60s American strategists assigned manned manoeuvring space vehicles with a payload of several tons the chief role in future military operations.

In 1963 the Pentagon concluded an agreement with NASA on joint efforts in the creation of manned orbital stations. In December of that year President Johnson authorised the military establishment to develop its own experimental manned orbital laboratory, independently of NASA. The work went on for five years. After spending 1,300 million dollars on it, the Pentagon cancelled the project when the American space programme was regeared for the development of the re-usable space shuttle transport system.

It is common knowledge that the Pentagon has carried out a large number of its space experiments on board the spacecraft *Mercury* and *Gemini*. After the programme for setting up a military space laboratory was scrapped, the use of manned spacecraft for military missions continued during the *Apollo* and *Skylab* flights.

The Pentagon's interest in manned space flights became even greater in the late '70s and early '80s. Special attention was given to the space shuttle programme, which was subordinated to the Pentagon's interests from the very outset. The Pentagon invested huge sums of money in it and is determining its course of development.

This fact was concealed in the United States for a number of years. However, the very first flights of spacecraft in this series left little doubt about the true nature of the programme. The Pentagon currently admits openly that it views the space shuttle system as an orbital beachhead called upon to play a major role in ensuring US military-strategic superiority.

Earlier, prior to the *Challenger* disaster (January 28, 1986), the four space shuttles (the other three were the *Columbia*, the *Discovery* and the *Atlantis*) had been intended to make 487 flights by 1991, of which about a third were to be for exclusively military purposes. Later the number of spacecraft of that type was to be increased to seven. However, this is no longer enough for US military plans, and work is now under way in America to develop new economical re-usable spacecraft, both manned and unmanned, such as the *Mini Shuttle*, *Cruiser*, *Space Plane*, etc., which will be characterised by prompt reaction, flexibility, high endurance and the ability to land on conventional airfields just like modern jetliners. Some of them are designed to be launched by space shuttles, others by single-start rocket boosters, and still others to take off from aircraft or from ordinary runways.

As a means of intelligence-gathering, such spacecraft can quickly obtain information on any part of the earth's surface from heights too great for planes and too low for satellites. They will be able, after take-off, to reach any given point above earth approximately 90 minutes after receiving a command and, while in space, to fly past any object orbiting the earth in less than six hours. According to American military experts, the advantage of this promising military spacecraft now being developed is that they can travel undetected over enemy territory at a speed of 27,000 kilometres an hour; they emit no characteristic radiation and leave no trace of exhaust fumes.

In early 1984 President Reagan took the decision to develop a long-term manned orbital station within the next 10 years. Its original crew of three or four is to be increased to eight or twelve.

They will be assigned an important role in testing the design and functioning of the future space-based ABM systems.

It is hoped in the Pentagon that the orbital battle stations, strategically positioned in outer space, like aircraft carriers on the high seas, will become the strike force of the space troops capable of mounting combat operations both in and from space. The stations will be able to defend not only themselves but other orbital objects as well.

The Pentagon schemes cover not only near space but also the moon and deep space. It is intended to set up an inhabited base on the moon to service and supply the future orbital battle stations as well as to maintain communications with them.

Since military operations will make deliveries from earth either limited or impossible, in the opinion of American military experts the supply and service bases should be set up secretly in deep space well in advance.

In the '80s Washington sharply stepped up its efforts aimed at militarising outer space. In October 1981 the United States adopted an arms build-up programme unprecedented in its scope. In addition to the modernisation and further build-up of the nuclear forces, it provides for the development of space-strike weapons, including combat antisatellites, improvements in the satellite communications and combat control systems, and prolonging the endurance of these systems and command posts in nuclear war conditions. Military preparations in this sphere were legalised in the July 4, 1982 presidential directive on a new US policy in the exploration and utilisation of outer space.

Plans for deploying nuclear weapons in outer space are now being discussed openly, in spite of the fact that such plans run counter to the existing international agreements prohibiting such actions. In particular, it is intended to use space shuttles and MX missiles to put nuclear warheads in waiting orbits as soon as the signal of an imminent nuclear missile attack is received. Washington strategists are not in the least embarrassed by the obvious adventuristic nature of such schemes. They will stop at nothing, not even suicide, to achieve the technical capability of delivering a nuclear strike to targets on earth within three to five minutes.

The development of antisatellite weapon systems started in the United States in 1958 and has gone on virtually unabated ever since. By April 1959 a *Bold Orion* missile was launched from a B-47 bomber to intercept the *Explorer-6* satellite. Two anti-satellite missiles were launched by the US Navy from a F-4 fighter plane under the Hi-Hoe programme. A *Thor* missile was launched from Johnston Island in the Pacific in 1963 to hit a space target (the last stage of the launch vehicle travelling in low earth orbit).

The missile passed the target within the effective range of the nuclear warhead which could have been installed on such a missile.

Between 1963 and 1967 the United States built an anti-satellite complex on Kwajalein atoll in the Pacific with the use of *Nike-Zeus* antimissiles. Later another complex of the same type based on *Thor* missiles was installed on Johnston Island. Both complexes were equipped with nuclear warheads. The nuclear antisatellites had to be abandoned, and, as the guidance systems improved, the United States began to develop non-nuclear devices for combatting space objects. These include traditional explosive devices detonated very close to the target, large sturdy metallic nets set up in outer space, target-seeking mini shells, etc.

THE SOVIET "STAR PEACE" PROGRAMME

As a viable alternative to the American "Star Wars" plans, which may well lead to a nuclear apocalypse, the Soviet Union has proposed a concrete "Star Peace" programme to pool the efforts of states in utilising outer space for peaceful purposes, for the benefit and in the interests of all peoples. The programme was laid out in a document submitted to the 40th Session of the UN General Assembly in August 1985. The document is entitled "The Main Lines and Principles of International Co-operation in the Peaceful Exploitation of Outer Space Under Conditions of Its Non-Militarisation". Later it was specified in a letter from the Chairman of the USSR Council of Ministers sent to the UN Secretary-General in June 1986.

The Soviet Union believes that the exploitation of outer space requires that all states adopt a new, genuinely global political outlook and reject such concepts as force and military superiority. This approach is dictated by three points.

First, the spread of the arms race to outer space cannot strengthen anyone's security or make nuclear weapons "impotent and obsolete".

Second, in present-day conditions no single state can defend itself by military-technical means alone.

Third, the appearance of space-strike weapons would sharply increase the risk of nuclear war breaking out, whip up the arms race, and erect obstacles in the way of disarmament, security, economic development, and peaceful co-operation in the exploitation of outer space.

THE SOVIET UNION CALLS FOR A STRICT BAN ON THE DEVELOPMENT, TESTING AND DEPLOYMENT OF SPACE STRIKE WEAPONS UNDER EFFECTIVE CONTROL,

INCLUDING INSPECTION OF THE APPROPRIATE LABORATORIES.

As early as December 1984, the 39th Session of the UN General Assembly adopted a resolution* which formulated for the first time the demand that all states should reject the use of force in their activities in outer space. As a step in this direction the USSR has proposed concluding an international agreement on the immunity of artificial satellites of the earth as well as on banning the development of new antisatellite systems and the elimination of existing ones.

The Soviet Union, urging the development of open co-operation in outer space accessible to all without discrimination, proposed the following material, political, legal, and organisational foundations for "Star Peace".

At the organisational stage it is proposed to study the needs of the world's nations in the use of space technology, taking into account the potential of modern space vehicles and the prospects for their development. To this end, it would be expedient to call an international conference or a special session of the UN General Assembly on matters of outer space no later than 1990. Or, such matters may be considered at any other suitable forum which would endorse a programme of action for the '90s and a general plan for another 15 years beyond that and establish a World Space Organisation (WSO).

The measures contained in the **first stage**, which could be undertaken by the Space Committee**, already envisage developing large-scale programmes for using space technology to solve the problems of scientific and technological development in the interests of all countries. Such programmes would involve:

— communications, navigation, a rescue service on earth, in the atmosphere and in outer space;

— remote-controlled probing of the earth for agricultural purposes, the exploitation of natural resources, including those of the World Ocean;

— the study and preservation of the earth's biosphere, the creation of a global weather service and early warning system for natural calamities;

* Resolution 39/59 of December 12, 1984, on the Use of Outer Space Exclusively for Peaceful Purposes, for the Benefit of Mankind.

** The Space Committee (the UN Committee on the Peaceful Uses of Outer Space) is an auxiliary body of the UN General Assembly set up at its 14th Session in keeping with Resolution 1472 of December 12, 1959.

— the development of new materials and technologies, including those for medicine and biology, with the use of a high vacuum and weightlessness;

— the study of outer space and celestial bodies, using geophysical methods and with the aid of unmanned interplanetary probes.

The USSR believes that it would be both fair and realistic for most of the funding for such international projects to come from the space powers and other economically developed countries. The developing countries would participate in such projects on favourable terms, while the least developed of them could take advantage of the scientific and technological results of research and development in the form of assistance.

The Soviet Union is prepared to share its achievements in outer space and provide its rockets for launching the space vehicles of other countries and international organisations (to be used for peaceful purposes) on mutually acceptable terms.

The **second stage**, which would cover the first half of the '90s', should introduce the practice of co-ordinating new space technology projects to achieve the more rational use of means and resources. Top priority would be given to projects for studying and preserving the biosphere, as these would pay off quickly and make it possible to gain experience for solving further problems.

At the second stage the World Space Organisation could begin co-ordinating national plans for the exploitation of outer space, set in motion the exchange of experience in this field, and assist countries making their first steps in the utilisation of outer space by granting them places for their instruments and for conducting experiments on board the space vehicles of other countries and by encouraging large-scale joint space projects. It could also establish contact and co-operation with other international organisations engaged in projects in the field of the peaceful exploitation of outer space.

The **third stage** would see the launching of space vehicles and the work of ground systems on specialised programmes in the various fields of space technology. These programmes would get under way on the principle of self-remuneration and would yield practical results. An organisational and material infrastructure would be built for large-scale joint space projects for scientific and industrial purposes, including the creation of orbital platforms and manned interplanetary spacecraft. Practical exploitation and utilisation of the moon and flights to other planets could begin within the first decades of the 21st century.

If the USSR-proposed programme were put into action, near

space would be used jointly in the interests of all nations and real conditions would be created for making human civilisation "inter-planetary" at the very start of the third millennium.

Efforts towards the establishment of a **World Space Organisation** would be a logical and vital step along this road. The USSR believes that it should be a universal inter-state organisation with a charter in the form of an international treaty. The WSO should be linked with the United Nations by an agreement on co-operation, and should co-ordinate efforts in individual specialised areas. It would be chiefly financed by the countries with large space potentials and other economically developed states.

The organisation's activities would be aimed at the peaceful exploitation of outer space and at monitoring the observance of agreements that would be reached on preventing the arms race from spreading to outer space. For such purposes the WSO could initially use technical facilities supplied by the space powers, and later, its own facilities.

The WSO would help all countries to make practical use of the achievements of space science and technology for the aims and needs of their social and economic development; it would help the developing states to participate directly in the exploitation of outer space.

For a Peaceful Outer Space!

The struggle to prevent the militarisation of outer space is the keynote of the programme for ending the arms race and bringing about disarmament. The Soviet State has been consistently following this programme on the world scene throughout its history.

When the first artificial satellite was launched exactly three decades ago, in October 1957, the Soviet Union stated its intention "to place scientific and technological achievements at the service of mankind's peaceful endeavours and secure conditions for co-operation among states in studying outer space for exclusively peaceful purposes". The CPSU Central Committee and the USSR Council of Ministers issued an address to the peoples and governments of all countries on the occasion of Yuri Gagarin's historic space flight on April 12, 1961. It stated that "we consider victories in the exploration of outer space the achievements not just of our people but of all mankind. We are only happy to place them at the service of all nations in the name of progress, happiness and benefit of all people on earth." And



Yuri Gagarin, the first man to fly to outer space

such statements made by the USSR were always matched in deed.

Already in the '50s and the '60s the Soviet Union made repeated concrete proposals aimed at preventing the use of the new sphere of human activity for military purposes. These proposals comprised in part a programme for general and complete disarmament.

For instance, **in April 1957**, before the first satellite was launched, the Soviet government presented memorandum to the Disarmament Committee on the implementation of partial disarmament measures. The Soviet Union proposed reaching agreement on the renunciation of the use of all types of nuclear weapons. Had this proposal then been accepted, ICBMs would not have become strategic weapons but rather rocket boosters used exclusively for peaceful purposes.

In March 1958 the Soviet government put forward a proposal on the question of banning the use of outer space for military purposes, the elimination of foreign military bases on the territories of other countries, and international co-operation in the study of outer space.

Within the framework of the UN alone the Soviet Union has put forward more than 100 proposals (draft resolutions of the UN General Assembly, draft international treaties, agreements, conventions, etc.) aimed at limiting the arms race and achieving disarmament, including the prevention of the militarisation of outer space. Many of them were used as a basis for drafting existing international agreements.

In addition to the United Nations, the Soviet proposals on limiting the use of outer space for military purposes have been discussed at the Disarmament Committee (the Conference on Disarmament since 1984) in Geneva. For instance, the draft treaty on general and complete disarmament under strict international control proposed by the USSR as far back as March 1962 envisaged that missiles and space vehicles be launched exclusively for peaceful purposes. To ensure that states comply with the treaty it was then proposed to set up inspection teams that would attend the launchings and have the right to examine every missile or satellite before lift-off.

In August 1981 the Soviet Union proposed including in the agenda of the 36th Session of the UN General Assembly an item on concluding a Treaty on the Prohibition of the Stationing of Weapons of Any Kind in Outer Space. At that time the Soviet Union submitted a draft of this treaty which contained provisions forbidding the participating states to put into orbit around the

earth objects with weapons of any kind or station such weapons on celestial bodies or in outer space in any way, including reusable, manned spacecraft—both existing ones and those of other types which the participating states might have in the future.

On December 9, 1981 the UN General Assembly, by a vast majority of votes, adopted a resolution supporting the Soviet proposal to conclude a treaty providing for effective measures to prevent the spread of the arms race to outer space.

In 1982 the Soviet Union submitted to the Special Disarmament Session of the UN General Assembly a memorandum on averting the growing nuclear threat and curbing the arms race. The memorandum contained a proposal on banning the placement of weapons of any kind in outer space. Consideration of the Soviet initiative also figured prominently at the Second UN Conference on the Exploration and Peaceful Uses of Outer Space held in Vienna in August 1982.

In January 1983 the Prague Meeting of the Political Consultative Committee of the Warsaw Treaty countries proposed concluding a treaty on the mutual non-use of armed force and the maintenance of peaceful relations between the Warsaw Treaty and NATO countries. It was stated that the treaty should include provisions on the non-first use of armed force against either side's craft at sea, in the air or in space and other such facilities, regardless of their location, as well as the pledge not to threaten the security of sea, air and space routes lying in areas under no country's jurisdiction.

In August 1983 the Soviet Union, confirming its readiness to solve the problem of antisatellite weapons in the most radical manner, undertook a unilateral commitment not to be the first to put any type of antisatellite weapon into outer space. In other words, the Soviet Union introduced a unilateral moratorium on such launchings, a moratorium that will remain in force as long as other states, including the US, refrain from putting any type of antisatellite weapon into outer space. What is more, the Soviet Union submitted to the 38th Session of the UN General Assembly a draft of the Treaty on the Prohibition of the Use of Force in Outer Space and from Space Against the Earth in furtherance of the Soviet draft of 1981.

In June 1984 the Soviet Union proposed banning and eliminating an entire type of armament—space-strike weapons, including space-based antisatellite and ABM systems, as well as any ground, air or sea-based systems intended for hitting objects in space. The Soviet Union also suggested holding Soviet-

American talks on the level of specially appointed delegations concerning the prevention of the militarisation of outer space. The question of the complete mutual renunciation of antisatellite systems was also to be decided at these talks. In an effort to create a favourable climate for the negotiations, it was proposed that a moratorium on the testing and deployment of space weapons be introduced the day these negotiations opened. It was noted that if other states acceded to that moratorium, it could provide a basis for multilateral agreement.

In January 1985 the USSR and the USA agreed to holding bilateral negotiations in Geneva beginning in March 1985. These would deal with a range of problems concerning space and nuclear weapons, both strategic and medium-range. All those problems were to be dealt with in their interdependence. The object of the talks was to work out effective agreements aimed at preventing the arms race in outer space and ending it on earth, at limiting and reducing nuclear armaments, and at increasing strategic stability.

The Soviet Union did everything in its power to ensure that mutually acceptable agreements be reached. It put forward a number of concrete proposals on every aspect of the talks and suggested an extensive programme of measures aimed at solving all problems included in the agenda of the talks.

In the meantime, the United States merely talked about its readiness to negotiate, and even then only on the "rules" of the arms race in space, that is, when space-strike systems should be deployed, their type and number. Consequently, the US stand at the talks, not only does not contain any constructive elements; it constitutes an attempt to legalise the fatal "Star Wars" programme.

The ensuing deadlock gave rise to the question of whether the two sides should simply mark time or look for new ways to reach agreement. The Soviet Union chose the latter course, proposing an interim variant on the solution of the nuclear-missile disarmament problem. It was suggested to the American side that the two countries reach agreement on the non-withdrawal from the ABM Treaty of 1972 for at least 15 years, strictly adhering in the meantime to its limitations banning antisatellite systems and "space-to-earth" weapons. It was suggested that work in the field of the so-called "strategic defence initiative" be limited to laboratory research, that is, the threshold the United States has in fact already reached. Strategic offensive arms were to be held at equal levels and the problem of intermediate-range missiles was to be decided separately.



"Star Wars" imperil life on earth. The peoples of the world come out in favour of "Star Peace"

A qualitatively new situation developed around these key issues of world politics after the Soviet-American summit in Reykjavik in October 1986. The Soviet Union, demonstrating its sincere desire to reach agreement, tabled new compromise proposals which took into full account the concerns of the American side and would make it possible to achieve an accord on such key issues as the 50-per-cent reduction of strategic offensive arms within five years and their full elimination by 1996, as well as the elimination of the Soviet and American medium-range missiles in Europe. Because this matter concerns those weapons which constitute the core of the USSR national defence and in order to rule out any possibility of creating a new type of weapon capable of giving one side military superiority, the Soviet Union proposed very strict international control over this process and consolidation of the terms of the open-ended Soviet-American ABM Treaty of 1972. First, the two sides should pledge not to abandon the treaty within the 10 years needed to reduce and eliminate strategic nuclear weapons. Second, the two sides should observe the provisions of the treaty on refraining from the development and deployment of ABM space systems, limiting themselves instead to laboratory research and testing.

Regrettably, the accord nearly achieved in Reykjavik on the reduction and elimination of nuclear weapons failed to materialise into agreements binding for both sides. The sole reason for this was the stubborn reluctance of the US Administration to create conditions for implementing those agreements by consolidating the terms of the ABM Treaty and assuming appropriate commitments identical for both sides.

"After Reykjavik," said Mikhail Gorbachev, "the notorious SDI appeared even more clearly before us all as a symbol of obstruction to the cause of peace, as an epitome of militarist designs and the reluctance to remove the nuclear threat looming over mankind. One cannot perceive it otherwise. This is the most important lesson of the meeting in Reykjavik... The meeting was a major event. A re-assessment took place. A qualitatively different situation developed. No one can continue to act as he did before. It prepared a possible step forward, towards a real shift for the better—if the United States would finally assume realistic positions and abandon chimerical assessments."

* * *

In this nuclear and space age the successful and comprehensive solution to the problem of outer space exploration requires not only the joint effort of all peoples and states; it also calls for a restructuring of long-established modes of thought and for the moulding of new, modern ones.

Each time cosmonauts return from their missions they speak of the incomparable beauty of our planet. They all point out how very small and defenceless it appears in the boundless expanses of the universe. At a time when imperialism is driving the world towards the disaster of an arms race in every sphere, the people of the earth should feel with particular acuteness the unity of their interests, the integrity of world civilisation and its fragility, their full responsibility for preventing the development and deployment of space-strike weapons, for preventing the militarisation of outer space.

War is not yet inevitable. However, the lessons of history show that it is necessary to eliminate the threat of war long before arms—nuclear, space or any other—are put into action.

The Soviet Union, having proposed a "Star Peace" programme as an alternative to "Star Wars", appealed to the nati-

ons of the world to protect outer space from any encroachments by militarists, and to prevent imperialist reactionary forces from extending military-political confrontation to outer space, for in present-day conditions this means sliding towards nuclear war.

Mankind, having ventured into outer space, has stood the test of scientific and technological maturity. Now it must take the test of moral, ethical and political maturity and keep outer space peaceful. We can only hope that it will pass this difficult test with honours.

Авдуевский Всеволод Сергеевич

Рудев Анатолий Иванович

«ПОКУШЕНИЕ НА ЗЕМЛЮ»

на английском языке

Цена 25 к.

THE EARTH IMPERILLED



Vsevolod S. Avduyevsky (b. 1920) is a member of the Academy of Sciences, winner of the Lenin and State Prizes of the USSR. He graduated from the Moscow Institute of Aviation and currently works on the scientific and technological problems of space flights, as well as the use of space probes in the national economy. A series of his works on the study of the planet Venus are widely known. He regularly contributes articles to the press on issues of the militarisation of outer space and international co-operation in its peaceful exploitation.



Anatoli I. Rudev (b. 1939) is a member of the Soviet Association of International Law, Cand. Sc. (Law). A graduate of the Moscow State University's School of Law, he contributes many articles to the press on the urgent issues of international space law.

In 1986 Avduyevsky and Rudev put out the brochure *Star Wars—A Madness and a Crime*, published in Russian in a large edition. This booklet has been written specially for the Novosti Press Agency Publishing House.



Novosti Press Agency Publishing House